

Important: Read all instructions prior to installation.

LuxOr LED Underwater Boat Light

Features

- 316L Marine Grade Stainless Steel
- 5 feet Power Wire (18AWG)
- Over-Temp Protection
- Poly-Carbonate Lens
- Internal Driver
- Waterproof IP68

Specifications

60W LED Underwater Boat Light	
Input Voltage	9 ~ 32 VDC
Current Draw	2.8 A @ 13.5VDC
Total Power Consumption	37.8 W @ 13.5VDC
Operating Temperature	-22° F ~ 122° F (-30° C ~ 50° C)
Available Colors	Blue, White
LED Lifetime	50,000 Hours
LED Brand	CREE
Warranty	2 Years
Dimensions	Dia. ø 3.69 in (9.4 cm)
	Thickness 0.67 in (1.7 cm)
Weight	1.43 lb (0.65 kg)

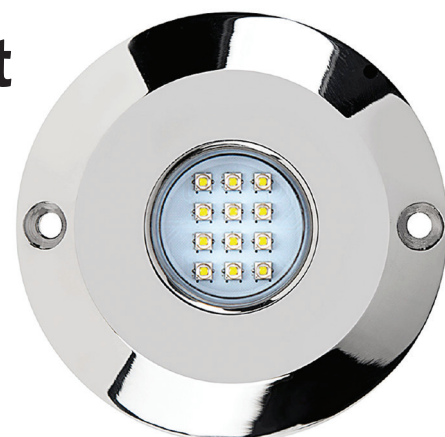

LED-RUWL-60-DC

Installation Instructions

IMPORTANT: Know your hull; most common type is fiberglass. Wood, metal and carbon fiber are other less common hull types. For metal or carbon fiber hull, first be sure to mount an insulating material between metal or carbon fiber surfaces and lights to prevent galvanic corrosion.

If the hull of your boat is metal or carbon fiber surface, you can use the plastic flat washers between hull and back of light.

If uncertain about type of hull, please contact boat manufacturer for assistance.

- Determine desired mounting location on boat's transom. Be sure to check actual draft water level if operating LED lights at speed. (See diagram below) Recommended mounting depth between 6-8" below waterline for best effect. Be sure that mounting location is free of any obstructions before drilling through hole. Mark center of desired location.

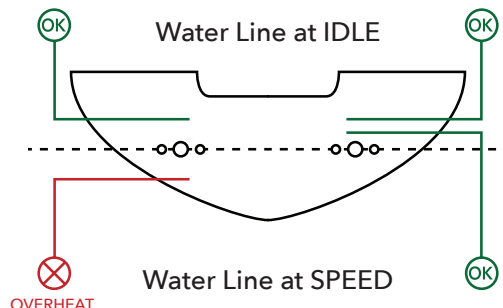

Parts Included

- 1 - Underwater Boat Light (LED-RUWL-60-DC)
- 2 - M5 Machine Screws
- 2 - M5 Locking Nuts
- 2 - Neoprene Washers
- 2 - M5 Flat Washers
- 2 - M5 Self Tapping Screws
- 2 - Neoprene T Washers

Recommended Tools (not included)

- Drill and Drill Bits
- Heavy Grit Sandpaper
- Isopropyl/Denatured
- Marine Sealant
- #2 Phillips Screwdriver
- Masking Tape
- Alcohol Lint Free Cloths
- Pencil (Wax Pencil recommended for fiberglass)

Caution

Lights must be submerged to avoid overheating. Use out of water will decrease led lifetime and cause early failure. Lights have over temperature protection (for testing purposes only) and will shut off when max temp (194° F / 90° C) is reached. Do not operate lights out of water for more than 2 minutes for testing. Lights will be hot if operated out of water for extended periods and will void all warranties. Installation of lights must be done while boat is out of water and dry. LuxOr Marine & RV is not responsible for any injury or property damage incurred due to improper installation.



Installation Instructions (continued)

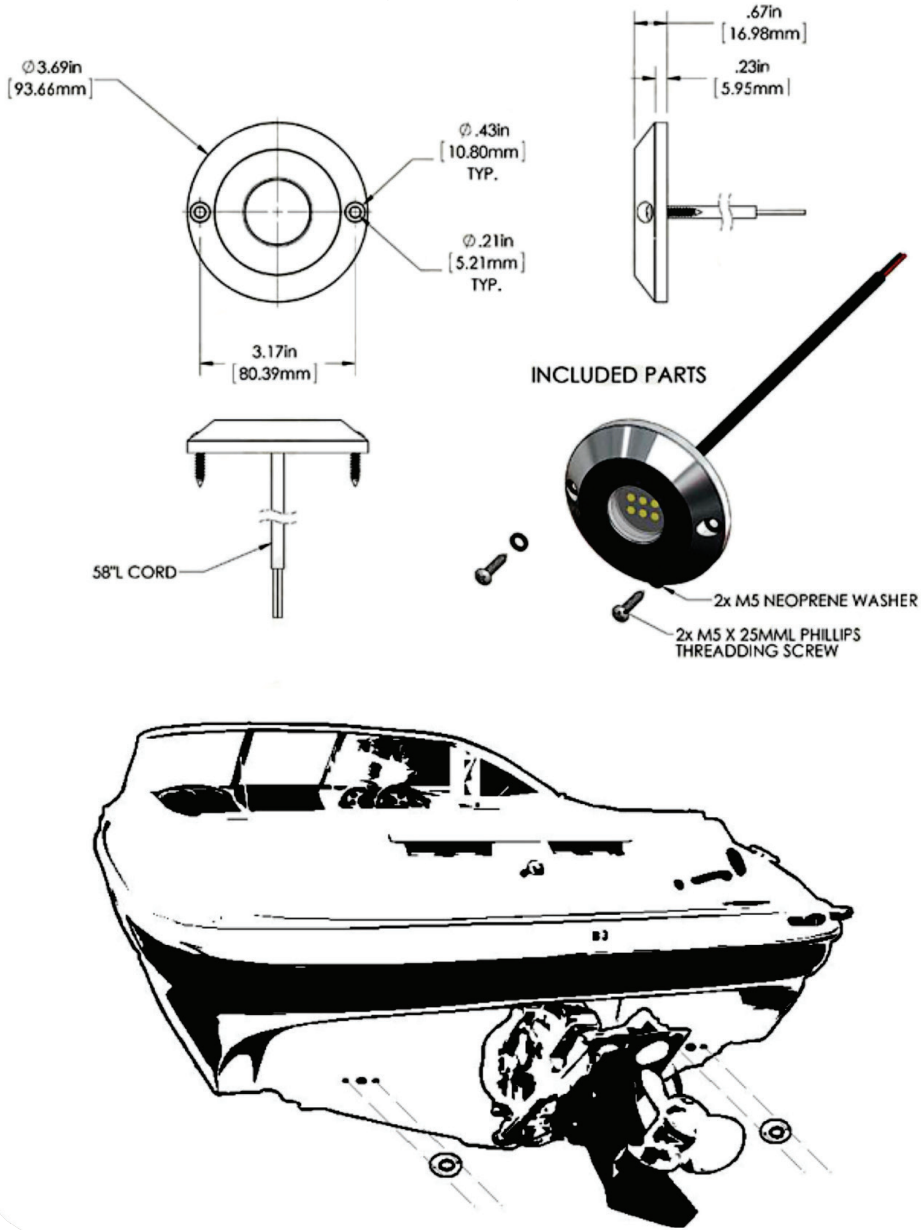

2. Drill 1/4" through hole in center of desired location and feed power wire through hole into boat. Hold light flush against transom, mark location for mounting screws, then remove light. Drill pilot holes for mounting screws to prevent cracking in fiberglass hulls.
3. Use heavy grit sandpaper to rough up the surface and to remove any debris from drilling. Clean area using alcohol and lint free cloth.
4. Apply uniform layer of marine sealant to back side of light, especially around mounting holes and wire connection. Also apply marine sealant to transom surface around pilot and through holes.
5. Feed power wire back through 1/4" hole into boat and press light against transom using uniform pressure. Install mounting screws with included neoprene washers and tighten light to transom.
6. Use sealant that has squeezed out from beneath light to create complete seal around outer edge of light. Remove any excess sealant.
7. Connect positive wire to positive battery terminal through fuse to switch (see wiring diagram below). Connect negative wire to negative battery terminal. Marine grade heat shrink butt connectors and ring terminals are recommended.
8. Ensure light is solidly attached to hull and that marine sealant has fully cured prior to putting boat in water. Lights may be tested briefly while out of water. Lights will overheat and shut down if operated out of water for more than testing.

Wiring Diagram

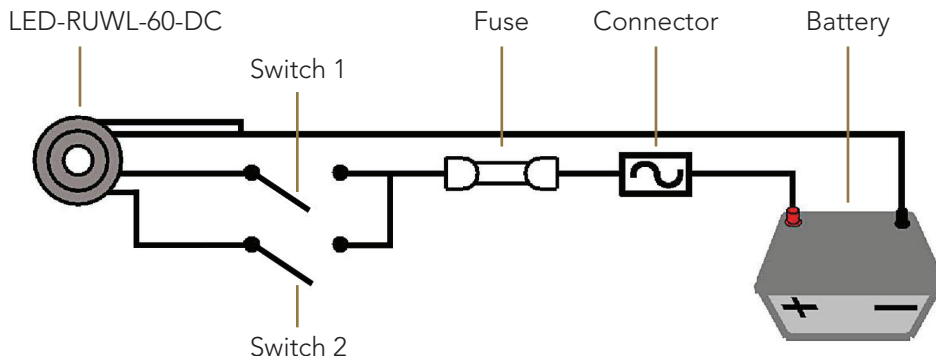

Connect the two negative wires together to the battery negative pole.

Wire color:

- White light : Red +; Black -
- Blue light : Green +; Blue -